

Energy Conservation Initiative (ECI) Project Summary

Emerson Hall Controls, Facility 1028E

What We Did: We replaced outdated space and central system controls served by Air Handling Unit-1 (AHU1) with new digital controls with occupancy sensors. Minimum and maximum airflows were adjusted to current standards on hoods and laboratory spaces. Lab air-flow control boxes were replaced with improved boxes which eliminated space air-flow balance issues. Pneumatic reheat valves were replaced with electric valves optimizing space temperature control. Occupancy sensors were installed to minimize energy use by allowing space temperatures and airflow set points to re-set during periods of un-occupancy.

What It Cost: \$215,000

How Long It Took: 8 months. Completed September 2013.

What We Saved: \$54,000 and 107 tons/per year carbon equivalent annually.

Benefits: Air flows and temperatures are now accurately controlled and minimized to reduce energy use and improve comfort and safety.

Updating the building HVAC controls provides increased functionality as well as contributing to a reduction in energy use.

Brian Flannigan
Facilities Manager
College of Agriculture
and Life Sciences

Emerson Hall Controls

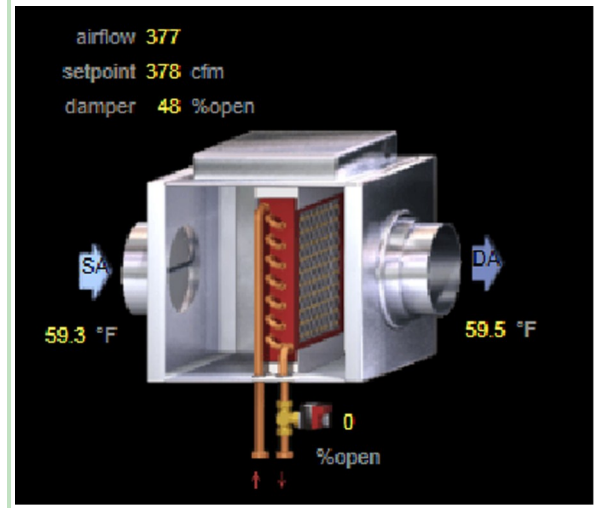

Emerson Hall Controls
Total Energy Use - Pre & Post ECI

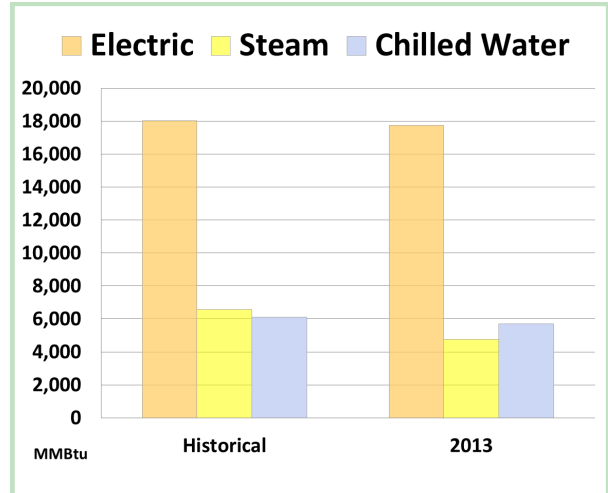

Emerson Hall Controls: ECI Savings Table

Utility	Historical Energy Use (MMBtu)	2013 Energy Use (MMBtu)	Energy Savings (MMBtu)	% REDUCTION	Historical (billed rates)	2013 Cost (billed)	Annual Savings \$	Equivalent # Homes
Electric	18,000	17,800	200	1%	\$370,600	\$364,000	\$6,000	5
Steam	6,600	4,800	1,800	27%	\$149,000	\$108,000	\$41,000	20
Chilled Water	6,100	5,700	400	7%	\$112,000	\$105,000	\$7,000	8
Totals	30,700	28,300	2,400	8%	\$631,000	\$577,000	\$54,000	33



Energy use based on project scope

Equivalent # Homes Savings based on average home use: 40 MMBtu Electric • 90 MMBtu Heat • 50 MMBtu Cooling

